

AMW 160/IX

12NC: 858763301000

EAN code: 8003437217586

Whirlpool

SENSING THE DIFFERENCE

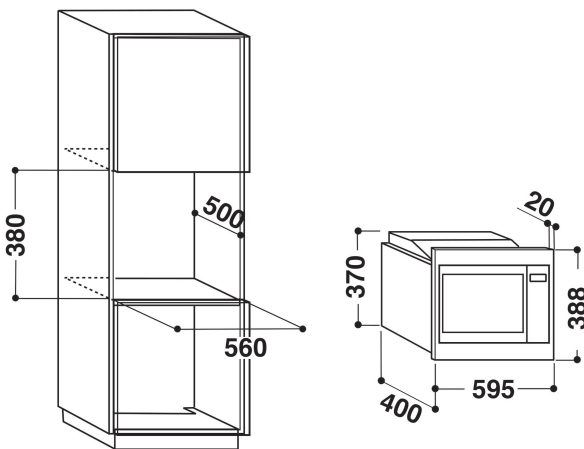

MAIN FEATURES

Product group	Microwave
Commercial code	AMW 160/IX
Main colour of product	Inox/Black
Type of micro-wave oven	MW+Grill function
Construction type	Built-in
Type of control	Electronic
Type of control setting and signalling devices	LED
Additional cooking method Grill	Yes
Crisp	No
Steam	No
Additional cooking method Fan cooking	No
Clock	Yes
Automatic programmes	Yes
Height of the product	388
Width of the product	595
Depth of the product	400
Minimum niche height	0
Minimum niche width	0
Niche depth	0
Net weight (kg)	18
Cavity capacity (l)	25
Turntable	Yes
Turntable diameter (mm)	315
Integrated Cleaning system	No

TECHNICAL FEATURES

Current (A)	13
Voltage (V)	230
Frequency (Hz)	50
Length of Electrical Supply Cord (cm)	110
Plug type	Schuko
Timer	Yes
Grill power (W)	1000
Type of grill	Heating element
Cavity material	Stainless steel
Interior light	Yes
Additional cooking method Grill	Yes
Position of interior lights	Right side

PERFORMANCES

6th Sense / Dynamic Intelligence	No
Number of power levels	6
Maximum micro-wave power (W)	900
Bread defrost	No
Jet defrost	Yes
Jet start	Yes